

FREQUENTLY ASKED QUESTIONS

July 2005 •

Q What is our warranty?

A Fontaine's warranty is for five years covering parts for material and workmanship. There are a few exceptions. See our existing warranty standard or call us at 1-800-874-9780 for more information.

Q What is the difference between the Wedge Stop Rod and Knock Out Rod and how do they work?

A The wedge stop rod serves two purposes. It serves as a slack adjustment and a knockout rod where as the "knock out rod" serves only as a emergency release in case the wheel should ever "bind up". Both type protrude through the side of the wheel opposite the side of the pull handle. The adjustable type requires a 1/4" gap between the tip of the locking wedge and the tip of the wedge stop rod when coupled to a 2" diameter pin. Proper adjusting can be achieved by turning the 15/16" (or 1-1/16") hex head bolt counter clock wise to increase the gap or clockwise to decrease the amount of gap. The 1/4" will allow the lock to automatically compensate for reasonable variances in king pin wear. The non-adjustable type will resemble a "Rivet Head" or " Carriage Bolt" type head. This type is self adjusting and will stay in constant contact with the tip of the locking wedge when the wheel is in the closed position. Both of these are spring loaded and may be struck with a hammer in the event the unit will not release when trying to uncouple from a trailer.

FREQUENTLY ASKED QUESTIONS

July 2005 •



My wheel is hard to open, what can I do to correct it?



Here are some things to help alleviate hard to open problems:

- a). Make sure a pre-service lubrication has been done to the unit before going into service. The internal locking components as well as the top surface of the wheel must be well lubricated to help ensure maximum performance and wearability.
- b). Make sure the driver is backing tight against the trailer after setting the trailer brakes. This will reduce any tension or pressure on the locking jaw and wedge.
- c). DO NOT dump chassis air bags before uncoupling from trailer.
- d). Make sure the Wedge Stop Rod is properly set to the recommended gap. (See TB-012)
- e). Make sure the truck and trailer are not in a bind or twist (No daylight between top plate and trailer plate).
- f). Check for any lower mount obstructions or interference underneath the wheel.
- g). Check for damage to the fifth wheel.

FREQUENTLY ASKED QUESTIONS

July 2005 •

Q Do you have a recommended maintenance procedure and what is it?

A Manufacturer recommended maintenance is at least every 90 days or 30,000 miles. All recommended practices are located in the Fifth Wheel Handbook supplied with every unit shipped or may be obtained by ordering from Fontaine.

Q How much vertical movement can I have between my fifth wheel plate and mounting plate?'

A Up to 1/2" vertical movement is possible. This movement helps to reduce negative load stresses that can be harmful not only to the fifth wheel assembly, but to the truck frame also. This feature can only be found on Fontaine products.

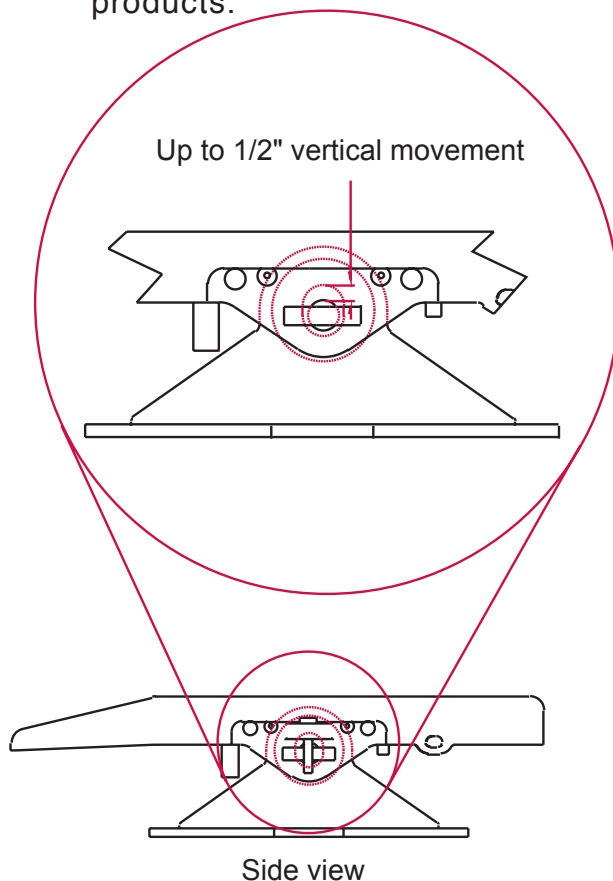

Note: Any movement beyond the specified dimension may be due to wear or other problem. Steps should be taken to determine the cause.

This dimension is to be used as a reference for service criteria only. For DOT out of service criteria, please consult the following website www.cvsa.org.

FREQUENTLY ASKED QUESTIONS

July 2005 •

Q How much vertical movement can I have between my slide rail and slide bracket?

A Up to 3/16" vertical movement is possible.

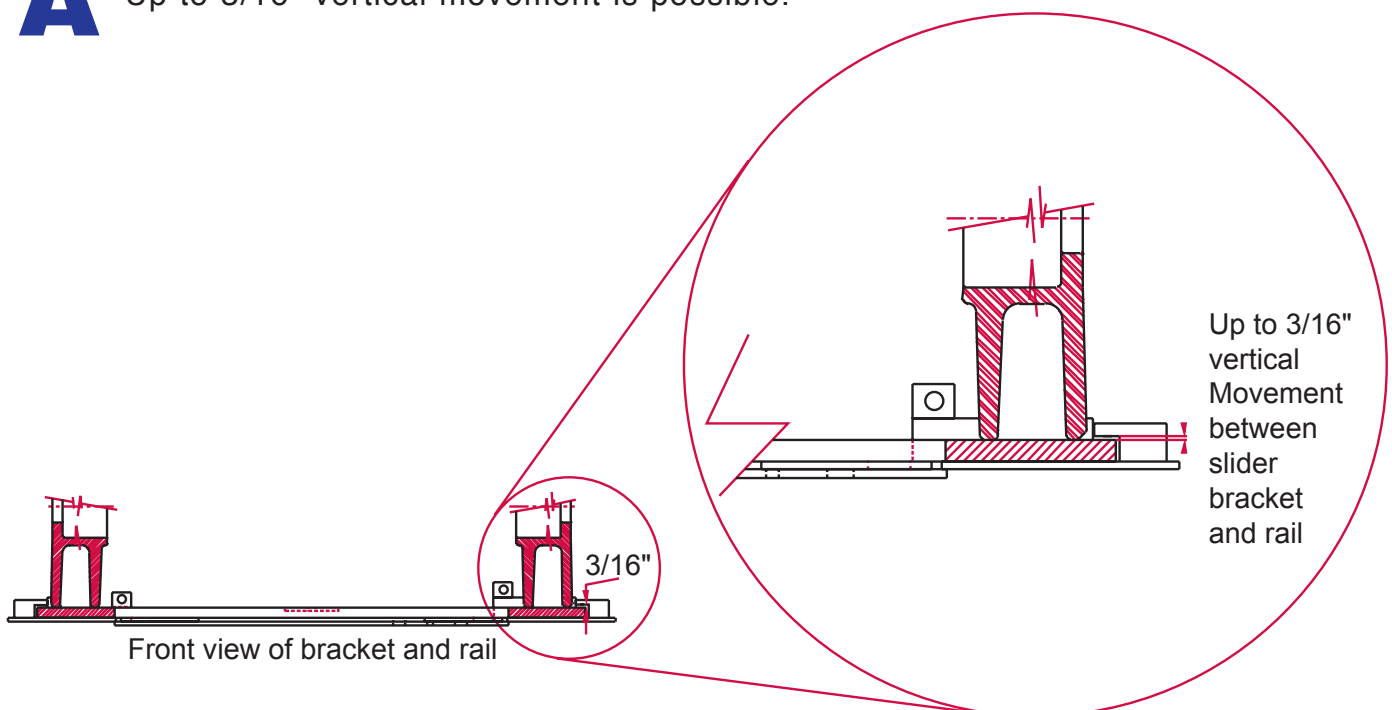

Note: Any movement beyond the specified dimension may be due to wear or other problem. Steps should be taken to determine the cause.

This dimension is to be used as a reference for service criteria only. For DOT out of service criteria, please consult the following website www.cvsa.org

FREQUENTLY ASKED QUESTIONS

July 2005 •

Q How much horizontal (side to side) movement can I have between my fifth wheel plate and mounting base?

A A. Up to 1/4" horizontal (side to side) movement is possible.

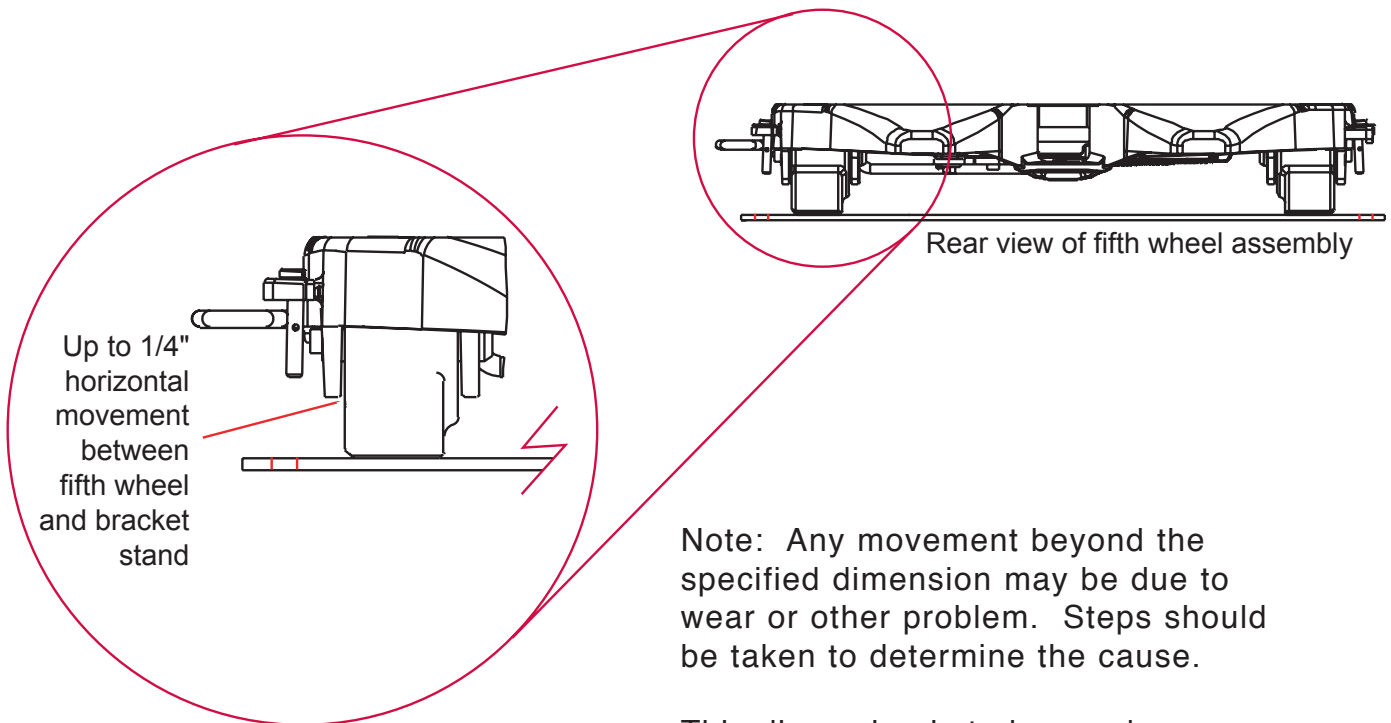

Note: Any movement beyond the specified dimension may be due to wear or other problem. Steps should be taken to determine the cause.

This dimension is to be used as a reference for service criteria only. For DOT out of service criteria, please consult the following website www.cvsa.org

FREQUENTLY ASKED QUESTIONS

July 2005 •

Q How much horizontal (side to side) movement can I have between my slide rail and slide bracket?

A Up to 5/16" horizontal (side to side) movement is possible between the slide rail and slide bracket.

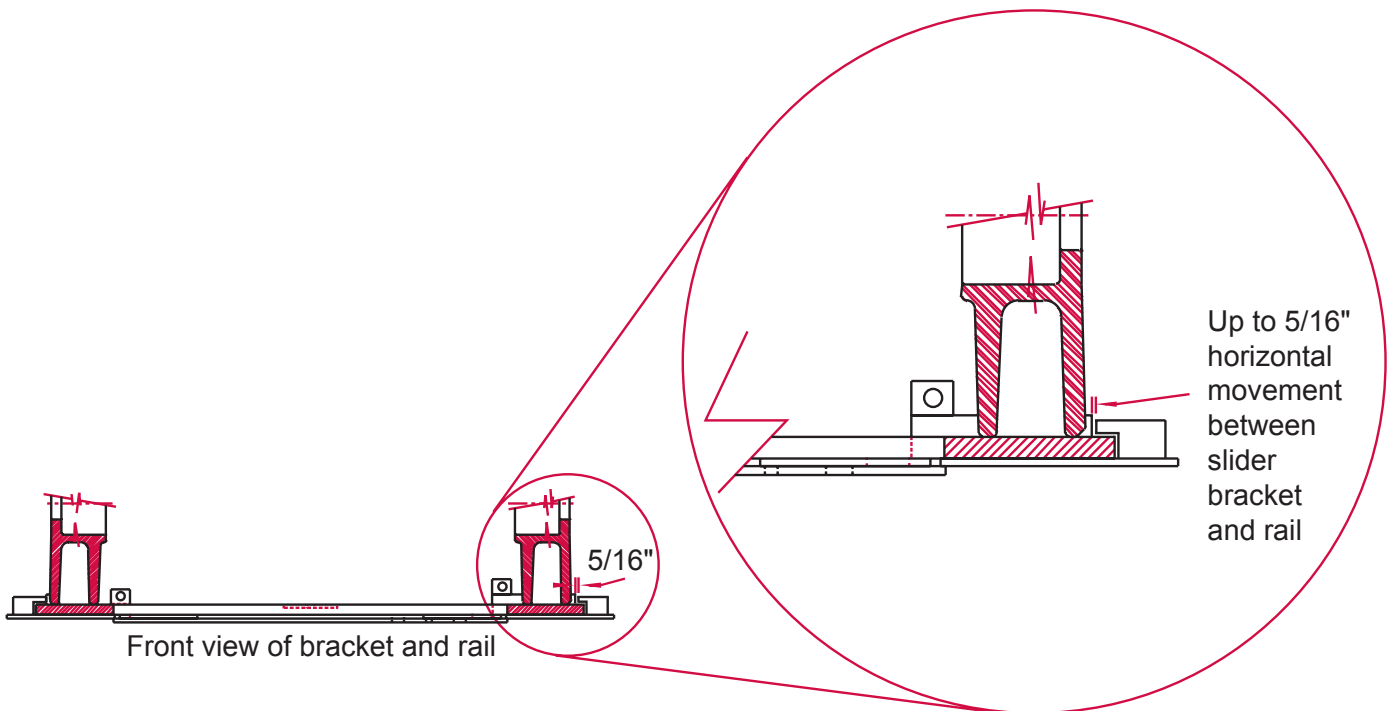

Note: Any movement beyond the specified dimension may be due to wear or other problem. Steps should be taken to determine the cause.

This dimension is to be used as a reference for service criteria only. For DOT out of service criteria, please consult the following website www.cvsa.org

FREQUENTLY ASKED QUESTIONS

July 2005 •

Q How can I tell if my wheel is fully locked?

A If the wheel is a No-Slack® II (6000 or 7000 Series) the Locking jaw and wedge must be fully across the throat of the wheel. In addition, the pull handle must be within 1" of the skirt of the wheel. The pull handle should be used as a positive lock indicator.

If the wheel is a No-Slack® (5000 or 5092 Series) the locking jaw and wedge should be fully across the throat of the wheel. In addition, the bottom section of the (2) piece pull handle should be in and down behind the triangular piece located just inside the fifth wheel skirt.

No-Slack® II Fifth Wheel Fully Closed

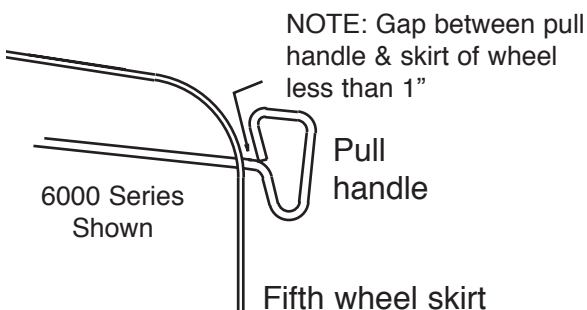

No-Slack® II Fifth Wheel Not Fully Closed

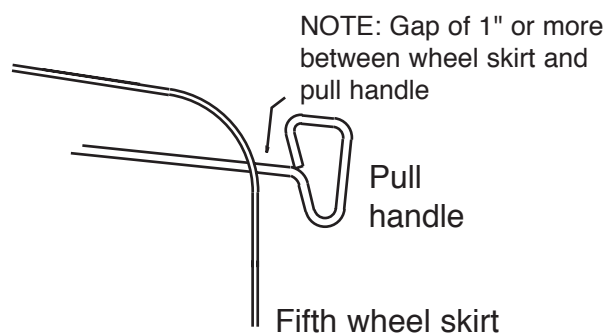

No-Slack® Fifth Wheel Fully Closed

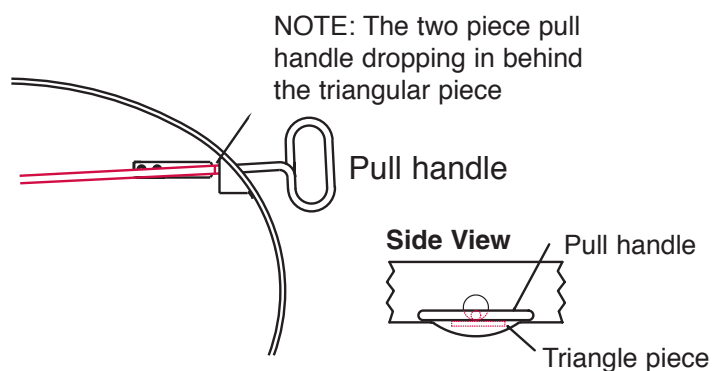

No-Slack® Fifth Wheel Not Closed

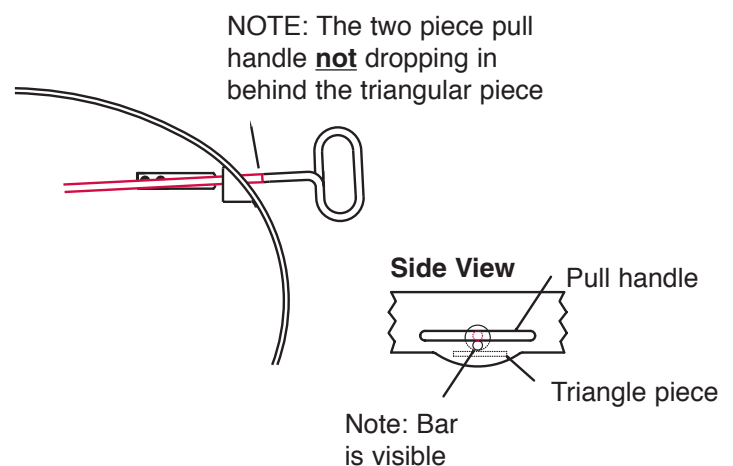

FREQUENTLY ASKED QUESTIONS

July 2005 •

Q Which fifth wheel is best for my application?

A Fontaine has an application guide that be obtained on our web site or by calling us at 1-800-874-9780.

Q My bracket bushings are worn out, can they be replaced under warranty?

A No. Contrary to what some people may think, the bracket bushings are a wear item and therefore not warrantable. The bushings are not a structural component. They help reduce negative load stresses that can be harmful to the fifth wheel assembly and keep the bracket pins from making unnecessary noise from vibrations.

Q How much wear is allowed on the bracket pins?

A Any visible wear that allows the fifth wheel to exceed the 1/2" maximum vertical movement between the wheel and base stand or any apparent deformation or material separation requires the pins to be replaced.

FREQUENTLY ASKED QUESTIONS

July 2005 •

Q I want to change the height of my fifth wheel, how can I do so?

A Changing fifth wheel height can be as simple as changing the brackets. It all depends on the type of application, style of fifth wheel and the type of existing base. These factors will determine just how high or low you can go.

Q Which rebuild kit do I need for the fifth wheel I have?

A All No-Slack® (5000 Series) fifth wheels use a KIT-RPR-5092
All No-Slack® II (6000/7000 Series) fifth wheels use a KIT-RPR-6000
You must use L or R after the last digit in the part number to specify a left or right opening kit.

FREQUENTLY ASKED QUESTIONS

July 2005 •

Q Can I use a Fontaine wheel on a Holland or ASF mount?

A NO, they are not interchangeable.

Q Is the 3000 series fifth wheel interchangeable with No-Slack® & No-Slack® II series fifth wheel mounting brackets?

A No, they are not interchangeable.

FREQUENTLY ASKED QUESTIONS

July 2005 •

Q Where can I find the fifth wheel model and serial number?

A The fifth wheel model number can be located on a rectangular tag attached to the front skirt of the fifth wheel. Some models carry an extra tag which may be found on the bottom side of the wheel located on the front or rear cross members. The serial number is etched in 1/2" digits onto the side of the right hand toe of the fifth wheel.

Q How do the primary and secondary locks work on the type of wheel I have?

A The No-Slack® (5000 Series) and No-Slack® II (6000/7000 Series) model wheels carry the same primary locks. The primary lock is the jaw and wedge itself. Between the mating surfaces of the two are small serration's. The geometry of the serration's keeps the wheel from being able to come open when the wheel is in the fully closed position.

The No-Slack® carries a (2) piece pull handle in which the bottom section when fully closed will drop in and down behind a small triangular piece located just inside the skirt of the wheel. This serves as a secondary lock.

The No-Slack® II has a slightly different feature to serve as a secondary lock. A rotating latch located on the front on the operating handle serves as a positive stop which will only release when activated by the pull handle. The use of the pull handle allows the latch to rotate enough to bypass its stop and open the wheel. If the pull handle is against the skirt of the wheel after coupling the secondary latch should be engaged. **ALWAYS BE SURE TO CHECK THE PRIMARY AND SECONDARY LOCKS AFTER COUPLING.**

FREQUENTLY ASKED QUESTIONS

July 2005 •

Q How much wear is allowed for a king pin?

A Worn king pins can cause various problems. It is recommended that king pins with .080" of wear (1.920" minimum diameter) be refurbished or replaced because of the potential premature wear or damage that the wheel may incur. DOT out of service criteria is .125" (1.875" minimum diameter).

FREQUENTLY ASKED QUESTIONS

July 2005 •

Q How much wear is allowed in the fifth wheel bearing pocket?

A If wear is evident at any point in the bearing pocket channel that does not allow lubricant to flow evenly, then steps should be taken to ensure unit is discarded. **Failure to do so will cause damage to the mounting bracket stand(s).**

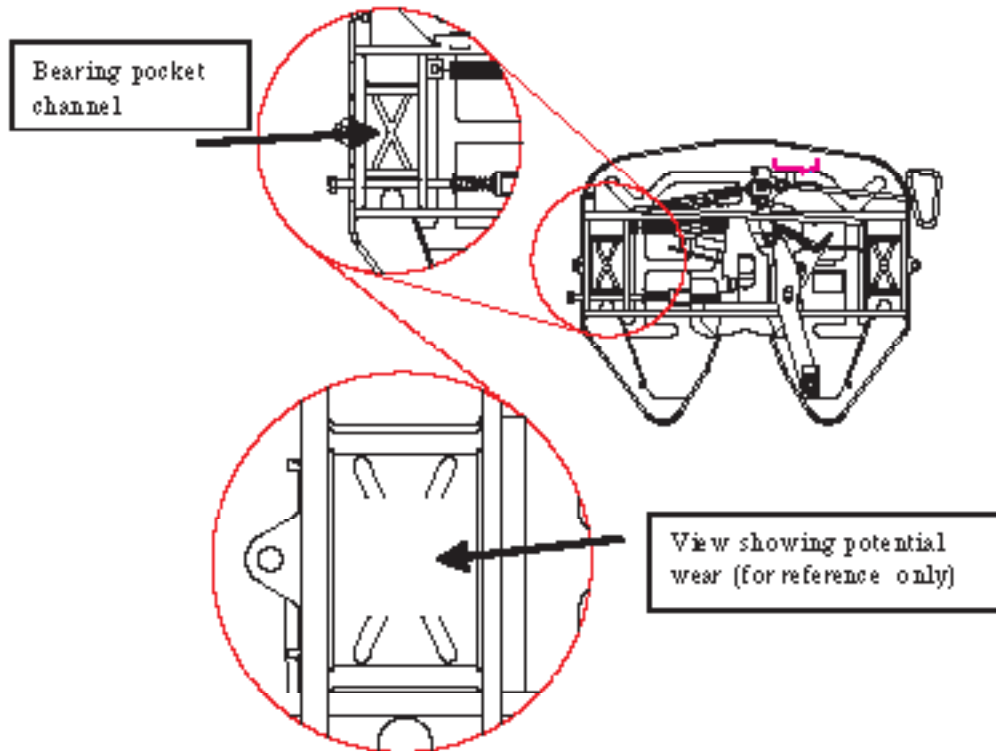

FREQUENTLY ASKED QUESTIONS

July 2005 •

Q How much stationary jaw wear is allowed until rebuilding the fifth wheel will not eliminate slack/movement between the trailer kingpin and locking mechanism?

A After determining the fifth wheel is in need of rebuilding, install the new jaw and wedge contained in the No-Slack® II kit (KIT-RPR-6000L or R).

Using the following steps, assemble the fifth wheel:

1. Insert a 2" test kingpin or plug
2. Insert the new jaw, then the wedge
3. Reinstall the timer, then the operating handle. Bolt the rear portion of the operating handle into place.

With the fifth wheel in the fully closed position, use the illustration below to determine if the unit is within usable specifications.

If gap is less than 5/16" at any point along indicated area, then fifth wheel must be replaced

