

## Fontaine® Ultra NT: 3000 Series and Ultra LT Replacement

The Fontaine® Ultra NT offers the benefits of a lightweight fifth wheel assembly (when coupled to an appropriate lower assembly) and incorporates the familiar Fontaine® No-Slack II locking mechanism. It can be used as a replacement wheel for the 3000 series wheel or the Ultra LT wheel as it fits on the following lower assemblies: ASB<sup>1</sup>, APB, SMB, LWO and LWI.

When installing Fontaine Aftermarket products, it is important to use all new items contained in the kit. Do not re-use similar items from the product to be replaced. This can be illustrated best by the different bracket pin lengths of the Ultra NT and Ultra LT products. See Figure 1. When incorrectly used with the Ultra NT wheel, the longer Ultra LT bracket pins interfere with the locking mechanism of the Ultra NT, rendering the wheel inoperable.

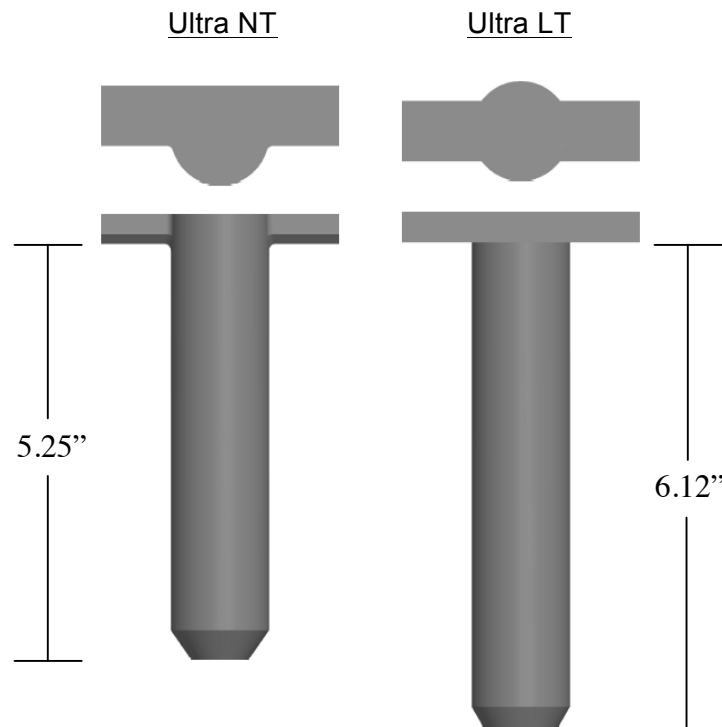

Figure 1: Ultra NT/LT Bracket Pin Lengths

<sup>1</sup> An air actuated NT should not be used with the ASB lower assembly as it will cause an interference.